

DUPERON® FLEXRAKE® LOW FLOW SYSTEM

The FlexRake Low Flow System provides another option for simple, affordable, and reliable automated bar screening and solids handling for low flow sites. It incorporates proven Duperon Adaptive Technology™ and a washer compactor specifically designed for this application and price point, maximizing value and performance.

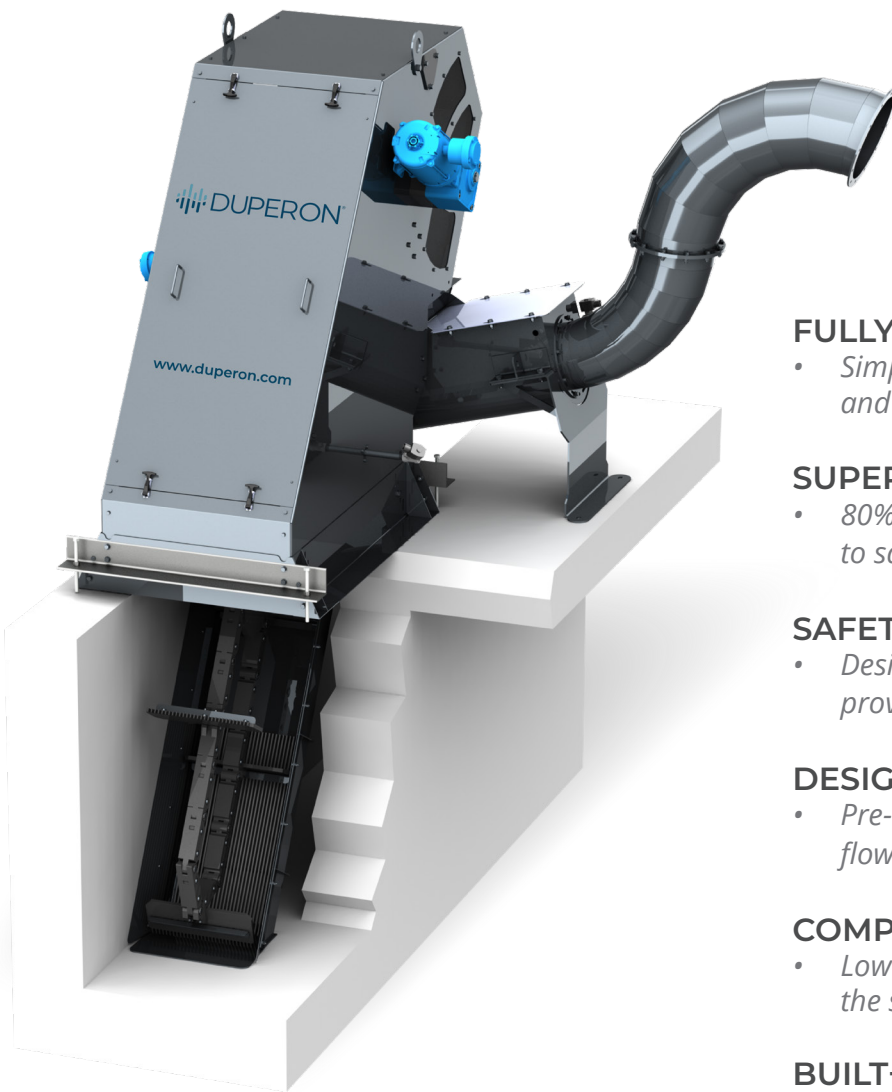

THE DUPERON DIFFERENCE

FULLY AUTOMATED SOLUTION

- *Simple and cost-effective mechanical bar screen and washer compactor for low flow sites*

SUPERIOR WASHING AND COMPACTING

- *80% volume reduction and 60% weight reduction to save landfill disposal costs*

SAFETY FACTOR

- *Designed to handle 4 MGD peaking events to provide peace of mind during wet weather*

DESIGNED FOR DUTY

- *Pre-engineered and sized to perform in channels, flows and conditions for small communities*

COMPACT SYSTEM

- *Low profile, integrated system with a footprint half the size of in-channel auger style equipment*

BUILT-IN FLEXIBILITY

- *Flexible pre-engineered design with options to fit your site needs*

THE DUPERON® FLEXRAKE® LOW FLOW FEATURES

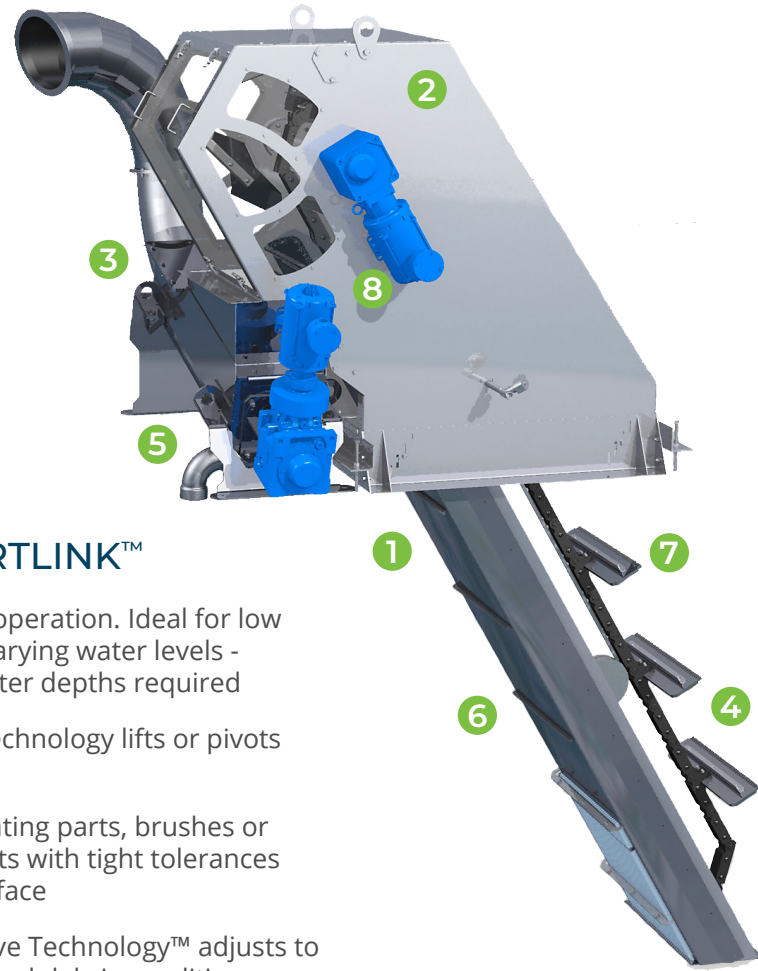

- 1 500 lb. lifting capability
- 2 Integral enclosure provides full containment and allowing access thru removable panels
- 3 Front-clean, front-return means no debris carryover
- 4 FlexRake Adaptive Technology™ adjusts to a range of flow and debris conditions
- 5 Stainless steel and corrosive-resistant materials of construction
- 6 Uses hydraulically efficient teardrop shaped bars
- 7 Thru-Bar™ Scrapers keep face of screen, sides of bar and cross-members clean
- 8 Energy efficient 1/4 hp motor

BENEFITS OF UHMW SMARTLINK™

- Allows for “dry” operation. Ideal for low flow sites with varying water levels - no minimum water depths required
- Jam Evasion™ Technology lifts or pivots around debris
- No complex rotating parts, brushes or wear components with tight tolerances below water surface
- FlexRake Adaptive Technology™ adjusts to a range of flow and debris conditions

THE DUPERON® LOW FLOW WASHER COMPACTOR FEATURES

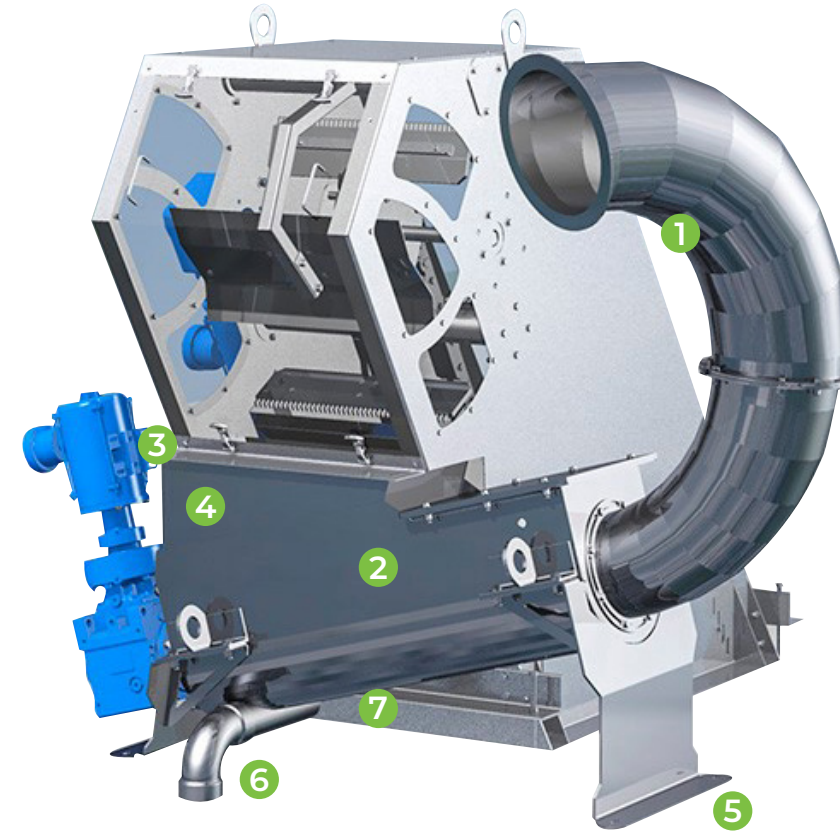

- 1 Discharge 5 ft. center line in any direction, even upstream
- 2 Floating bearing design self-centers and accommodates irregular debris without binding
- 3 Customizable speed and wash settings to optimize cleaning based on site conditions
- 4 Over-sized hopper capacity reduces overflow potential
- 5 Engineered for minimum footprint
- 6 Anti-clogging drain connection
- 7 Self-cleaning strainer design eliminates maintenance-intensive brushes

FOR LOW FLOW SITES

COMPLETE SCREENING & SOLIDS HANDLING SYSTEM

LOW COST OF OWNERSHIP

With few parts, simple design and minimal maintenance, the FlexRake® Low Flow System is easy to install, own and operate by your crew

The FlexRake Low Flow is a front-clean, front-return mechanical bar screen. It features the SmartLink™ multifunctional link system, which eliminates underwater sprockets, bearings or tracks that create a fixed path of travel and are subject to fouling and/or jamming. The groundbreaking flex/pivot action of the Duperon FlexRake is unhampered by large debris. It is offered in a range of channel widths, depths and bar openings to meet the needs of small communities.

The pre-engineered Low Flow Washer Compactor is a perfect fit in size and capacity to receive screenings from the FlexRake Low Flow bar screen. It consists of a single auger with a floating bearing design to self-center and accommodate irregular debris. A self-cleaning strainer eliminates maintenance-intensive brushes. The washing chamber rinses screenings and returns fecal matter to the channel via an anti-clogging drain. The weight and back pressure from the debris in the chute generate compaction – there is no fixed sized compaction. The Low Flow Washer Compactor is integrated to run in coordination with the Low Flow (non-batch processing).

LOW FLOW WASHER COMPACTOR DISCHARGE CHUTE ACCESSORIES



HEAT BLANKET:

The discharge chute can be thermally protected from cold temperatures with the addition of the Heat Blanket with integral heat trace.



BAGGER:

The Bagger System attaches to the discharge chute for applications where bag dispensing and odor control are required. Included is a 90 meter length of continuous feed bags.



DROP SLEEVE:

This flexible Drop Sleeve is an economical way to direct and contain downward debris discharge. Also used where waste container hauling may cause damage to metal discharge chutes.

ADDITIONAL ACCESSORIES:

- Washer Compactor Open Channel Support Frame 304 SSSL - built to span open channels
- Washer Compactor Chute Extension 304 SSSL - 5 ft additional chute length
- Washer Compactor Plumbing Kit Fernco Elbow, ball valve and y-strainer
- Washer Compactor Hopper Spray Kit for use with sites that have high fecal

GENERAL

	FlexRake® Low Flow	Low Flow Washer Compactor
Average Flow Capacity:	1 MGD or less	5 ½ cu.ft/hr
Peak Flow Capacity:	4 MGD	8 cu.ft/hr
Bar Opening:	¼", ½", ¾", 1"	N/A
Channel Widths:	12", 18", 24"	N/A
Channel Depths:	2' to 6' (available in ½' increments)	N/A
Screenings Discharge Chute:	N/A	Positionable up to 5' center line in any direction
Maximum Liquid Level:	22"	N/A
Minimum Liquid Level:	0" (can run dry)	N/A

UTILITY

	¼ HP	½ HP
	1 PH/115 or 230 VAC	1 PH/115 or 230 VAC
	3 PH/240 or 480 VAC	3 PH/240 or 480 VAC
	TEFC, inverter duty	explosion proof, inverter duty

WATER

Water Supply:	Fecal breakdown sprayer (optional use) Filtered effluent screened At/below (150) micron 100 Mesh screen	Wash water Filtered effluent screened At/below (150) micron 100 Mesh screen
Supply Connection:	½" NPT male connection	½" NPT female connection -or - GHT ¾" female fitting for std garden hose
Consumption:	2-4 GPM	3-10 GPM
Required Pressure:	40-60 PSI	40-60 PSI
Drain Connection:	N/A	3" NPT

MATERIALS OF CONSTRUCTION

304 SSSL:	Enclosure, deadplate, closeouts (316 SSSL upgrade available)	Hopper, discharge chute
316 SSSL:	Teardrop shaped screen bars	N/A
UHMW:	SmartLink™	Auger supports

PERFORMANCE

Dry Solids:	N/A	Up to 60%
Mass/Weight Reduction:	N/A	Up to 70%
Volume Reduction:	N/A	Up to 80%
Odor/Fecal:	N/A	Significantly decreases odor/fecal Passes paint filter test